

GRAIN GUARD

FULL CENTRIFUGAL HEAVY DUTY MODELS

MODELS: 3HP, 5HP, 7HP, & 10HP
INSTALLATION, OPERATION, AND PARTS MANUAL

IMPORTANT: READ AND SAVE THESE INSTRUCTIONS

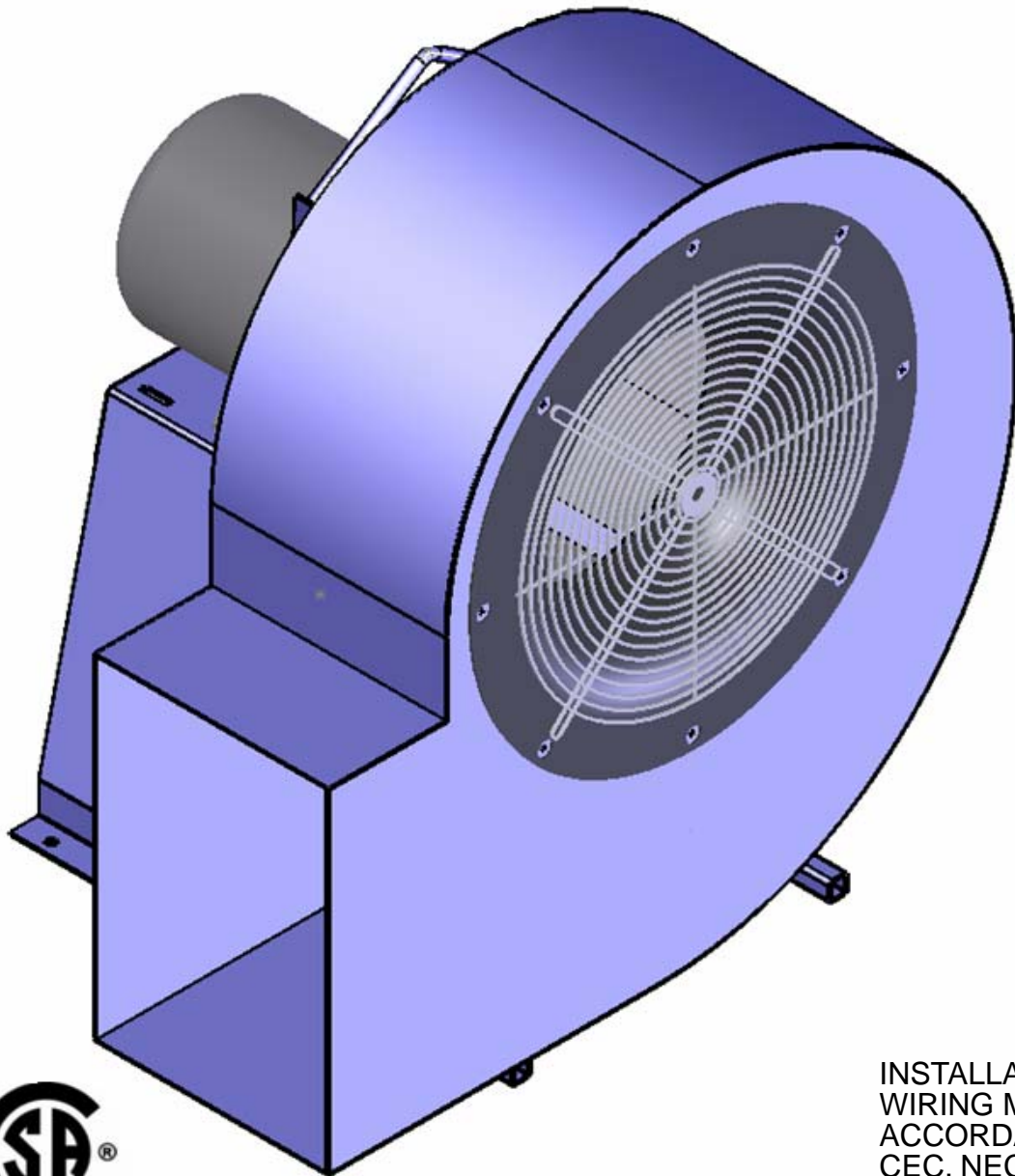

INSTALLATION AND
WIRING MUST BE IN
ACCORDANCE WITH
CEC, NEC AND LOCAL
ELECTRICAL CODES



Read this manual before using product. Failure to follow instructions and safety precautions can result in serious injury, death, or property damage. Keep manual for future reference.

Part Number: CNA-1813 R2

Revised: 19/10/10

This product has been designed and constructed according to general engineering standards^a. Other local regulations may apply and must be followed by the operator. We strongly recommend that all personnel associated with this equipment be trained in the correct operational and safety procedures required for this product. Periodic reviews of this manual with all employees should be standard practice. For your convenience, we include this sign-off sheet so you can record your periodic reviews.

Date	Employee Signature	Employer Signature

a. Standards include organizations such as the American Society of Agricultural and Biological Engineers, American National Standards Institute, Canadian Standards Association, International Organization for Standardization, and/or others.

TABLE OF CONTENTS

1. Introduction	5
2. Safety First.....	7
2.1. General Safety	8
2.2. Installation Safety	9
2.3. Operational & Maintenance Safety.....	9
2.4. Storage Safety.....	9
2.5. Bin Roof Safety	9
2.6. Safety Decal Locations.....	10
2.6.1. Decal Installation	10
2.6.2. Decal Locations	10
3. Installation	13
3.1. Before You Begin	13
3.2. Location & Mounting.....	13
3.3. Electric Motor Wiring	13
4. Operation	15
4.1. Start-Up	15
4.2. Break-In.....	15
4.3. Shutdown	16
4.4. Emergency Stop.....	16
4.5. Application Requirements	17
5. Maintenance & Storage.....	19
5.1. Maintenance.....	19
5.1.1. Cleaning	19
5.1.2. Servicing & Part Replacement.....	19
5.2. Storage.....	20
6. Troubleshooting	21
7. Appendix.....	23
7.1. Parts Lists.....	23
7.2. Electrical Schematics	27
7.3. Aeration Tips	28
Warranty.....	31

1. Introduction

Thank you for your purchase. This aeration fan is an excellent addition to any bin and it will allow you to harvest in damp conditions, maintain stored grain in peak condition, and prevent mold growth and insect infestation. With proper care during and after installation, your fan will provide you with many years of trouble-free service.

Safe, efficient, and trouble-free operation of your fan requires that you, and anyone else who will be involved with this equipment, read and understand all safety instructions and procedures contained within this manual. A sign-off form is provided on the inside front cover for your convenience.

Keep this manual handy for frequent reference and to review with new personnel. Call your local distributor or dealer if you need assistance or additional information.

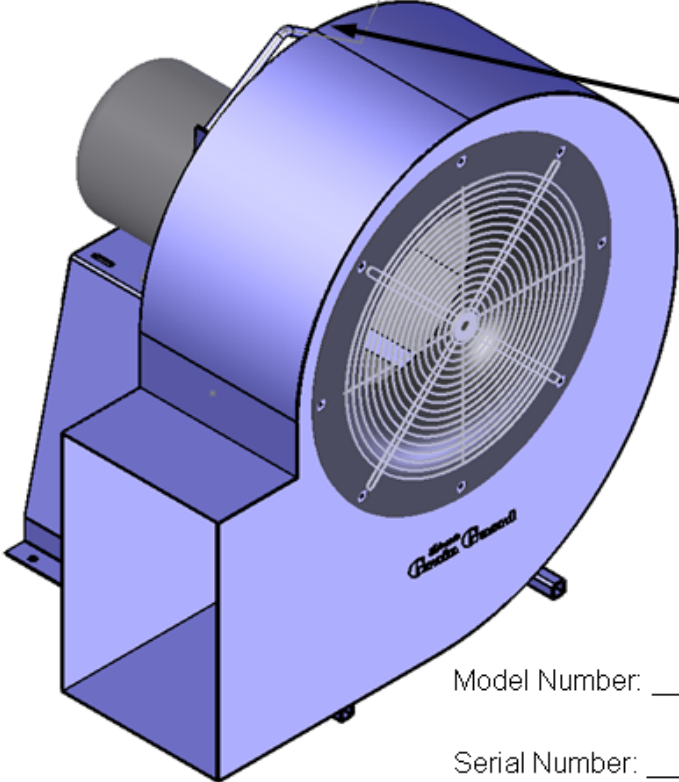

Serial Number located on CSA decal	
MODEL: C-18-251-1	SERIAL: 200020590
AMP RATING: 3020	CFM @ 4.0 N. WC
RATED SPEED: 3450 RPM	
AMP MAX HP: 3.1	MAX FROM 0 IN. TO 7.0 N. WC
THERMALLY PROTECTED: 3 H.P.	1 PHASE
17718	AMP MAX AT 208/230 VOLT MAX
MADE IN CANADA BY EDWARDS GROUP A DIV of AG GROWTH IND LETHBRIDGE ALBERTA	
ENC. 3R	OUTDOOR USE
LR52151	

Model Number: _____

Serial Number: _____
(found on CSA decal)

Date Purchased: _____

Dealer Name: _____

2. Safety First



The Safety Alert symbol to the left identifies important safety messages on the product and in the manual. When you see this symbol, be alert to the possibility of personal injury or death. Follow the instructions in the safety messages. Why is SAFETY important to you?

Three big reasons:

- Accidents disable and kill.
- Accidents cost.
- Accidents can be avoided.

SIGNAL WORDS

Note the use of the signal words **DANGER**, **WARNING**, **CAUTION**, and **NOTICE** with the safety messages. The appropriate signal word for each message has been selected using the definitions below as a guideline.

The Safety Alert symbol means: "ATTENTION, BE ALERT! YOUR SAFETY IS INVOLVED".

DANGER



Indicates an imminently hazardous situation that, if not avoided, will result in serious injury or death.

WARNING



Indicates a hazardous situation that, if not avoided, could result in serious injury or death.

CAUTION



Indicates a hazardous situation that, if not avoided, may result in minor or moderate injury.

NOTICE

Indicates a potentially hazardous situation that, if not avoided, may result in property damage.

2.1. GENERAL SAFETY

Important: *The general safety section includes instructions that apply to all safety practices. Any instructions specific to a certain safety practice (e.g., assembly safety), can be found in the appropriate section. Always read the complete instructional sections and not just these safety summaries before doing anything with the equipment.*

YOU are responsible for the **SAFE** use and maintenance of your equipment. **YOU** must ensure that you and anyone else who is going to work around the equipment understands all procedures and related **SAFETY** information contained in this manual.

Remember, **YOU** are the key to safety. Good safety practices not only protect you, but also the people around you. Make these practices a working part of your safety program.

- It is the equipment owner and the operator's responsibility to read and understand **ALL** safety instructions, safety decals, and manuals and follow them before assembling, operating, or maintaining the equipment. All accidents can be avoided.
- Equipment owners must give instructions and review the information initially and annually with all personnel before allowing them to operate this product. Untrained users/operators expose themselves and bystanders to possible serious injury or death.
- Use this equipment for its intended purposes only.
- Do not modify the equipment in any way. Unauthorized modification may impair the function and/or safety, and could affect the life of the equipment. Any modification to the equipment voids the warranty.
- Do not allow children, spectators, or bystanders within the work area.
- Have a first-aid kit available for use should the need arise, and know how to use it.
- Provide a fire extinguisher for use in case of an accident. Store in a highly visible place.
- Wear appropriate protective gear. This list includes, but is not limited to:
 - a hard hat
 - gloves
 - protective shoes with slip-resistant soles
 - protective goggles
 - hearing protection
- For Powered Equipment: before servicing, adjusting, or repairing powered equipment, unplug, place all controls in neutral or off position, stop the engine or motor, remove ignition key or lock out power source, and wait for all moving parts to stop.



- Follow good shop practices:
 - keep service area clean and dry
 - be sure electrical outlets and tools are properly grounded
 - use adequate light for the job at hand
 - Think SAFETY! Work SAFELY!



2.2. INSTALLATION SAFETY

- Check all equipment for damage immediately upon arrival. Do not attempt to install a damaged item.
- Have 2 people handle the heavy, bulky components.

2.3. OPERATIONAL & MAINTENANCE SAFETY

- Ensure that electrical cords are in good condition; replace if necessary.
- Ensure the fan inlet is not plugged with any foreign material.
- Keep inlet screen in place at all times.
- Before resuming work, install and secure all guards. Keep guards in good working order.
- Ensure parts are in good condition and installed properly.

2.4. STORAGE SAFETY

- Store the unit in a dry, clean area away from human activity.
- Do not permit children to play on or around the stored machine.

2.5. BIN ROOF SAFETY

To prevent bin damage from aeration:

- Roof vents should be sized at 1 ft² for every 1000 ft³/min of air to minimize condensation.
- Operate fan as intended with positive pressure.
 - Positive pressure is shown in Figure 1.1, with air entering through the bottom and exiting out the top.
 - Fan pressure can be reversed and the fan can be operated with negative pressure if wiring is modified. However, reversing fan operation can damage the roof.
- Roof vents may become partially or fully blocked with ice in temperatures below freezing with high humidity conditions. Discontinue operation of fan in these conditions or add supplemental heat.
- Roof damage may occur to the bin if procedures in this manual are not properly followed. Operate fan only as described in this manual with positive pressure and using bin roof vents.

Bin damage due to improper fan operation is not covered by warranty.

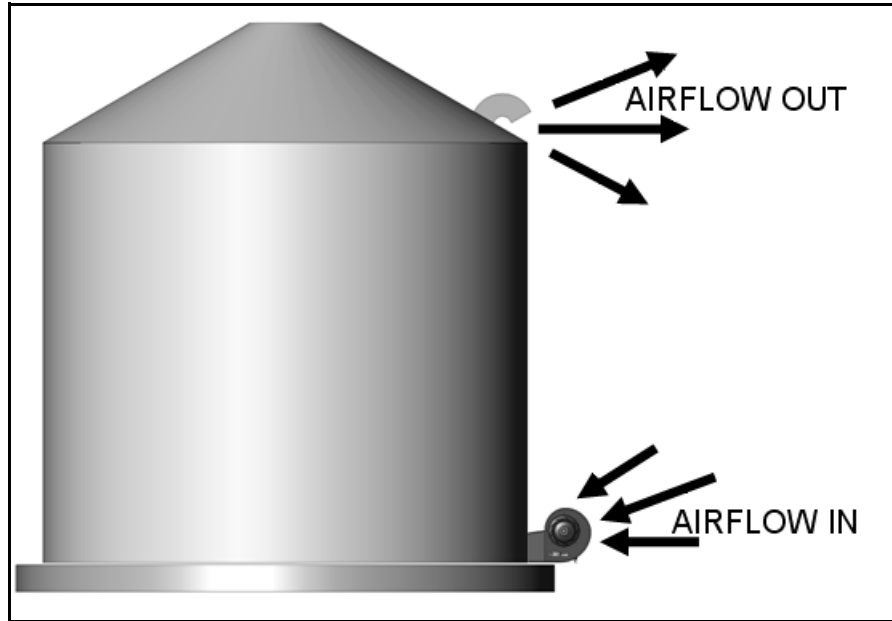

Figure 2.1

2.6. SAFETY DECAL LOCATIONS

- Keep safety decals clean and legible at all times.
- Replace safety decals that are missing or have become illegible. See decal location figures that follow.
- Replaced parts must display the same decal(s) as the original part.
- Safety decals are available from your distributor, dealer, or factory.

2.6.1. DECAL INSTALLATION

1. Decal area must be clean and dry, with a temperature above 10°C (50°F).
2. Decide on the exact position before you remove the backing paper.
3. Align the decal over the specified area and carefully press the small portion with the exposed sticky backing in place.
4. Slowly peel back the remaining paper and carefully smooth the remaining portion of the decal in place.
5. Small air pockets can be pierced with a pin and smoothed out using the sign backing paper.

2.6.2. DECAL LOCATIONS

Replicas of the safety decals that are attached to the equipment are shown in the figure(s) that follow. Good safety requires that you familiarize yourself with the various safety decals and the areas or particular functions that the decals apply to as well as the safety precautions that must be taken to avoid serious, injury, death, or damage.

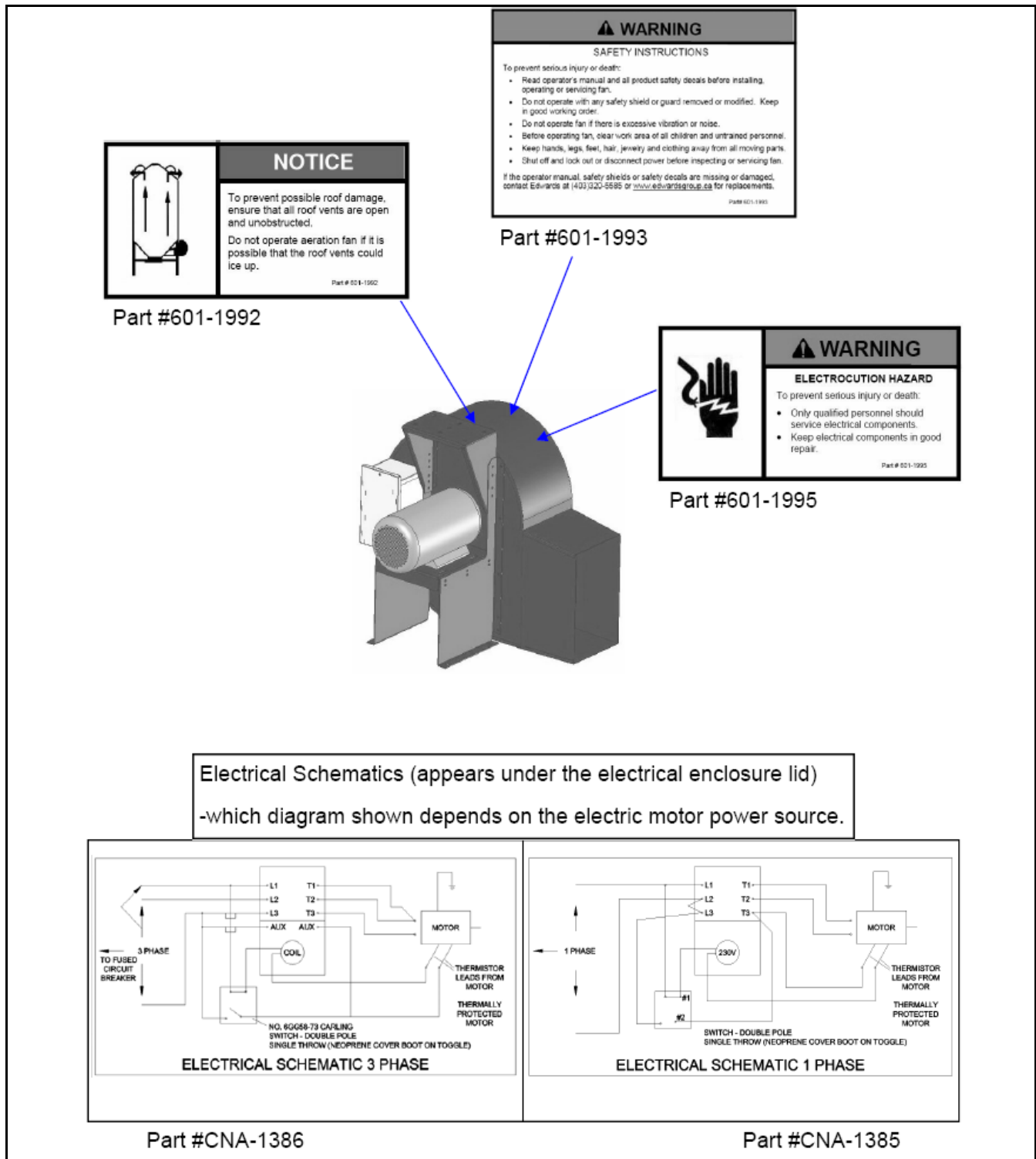

Figure 2.2 Safety Decal Locations

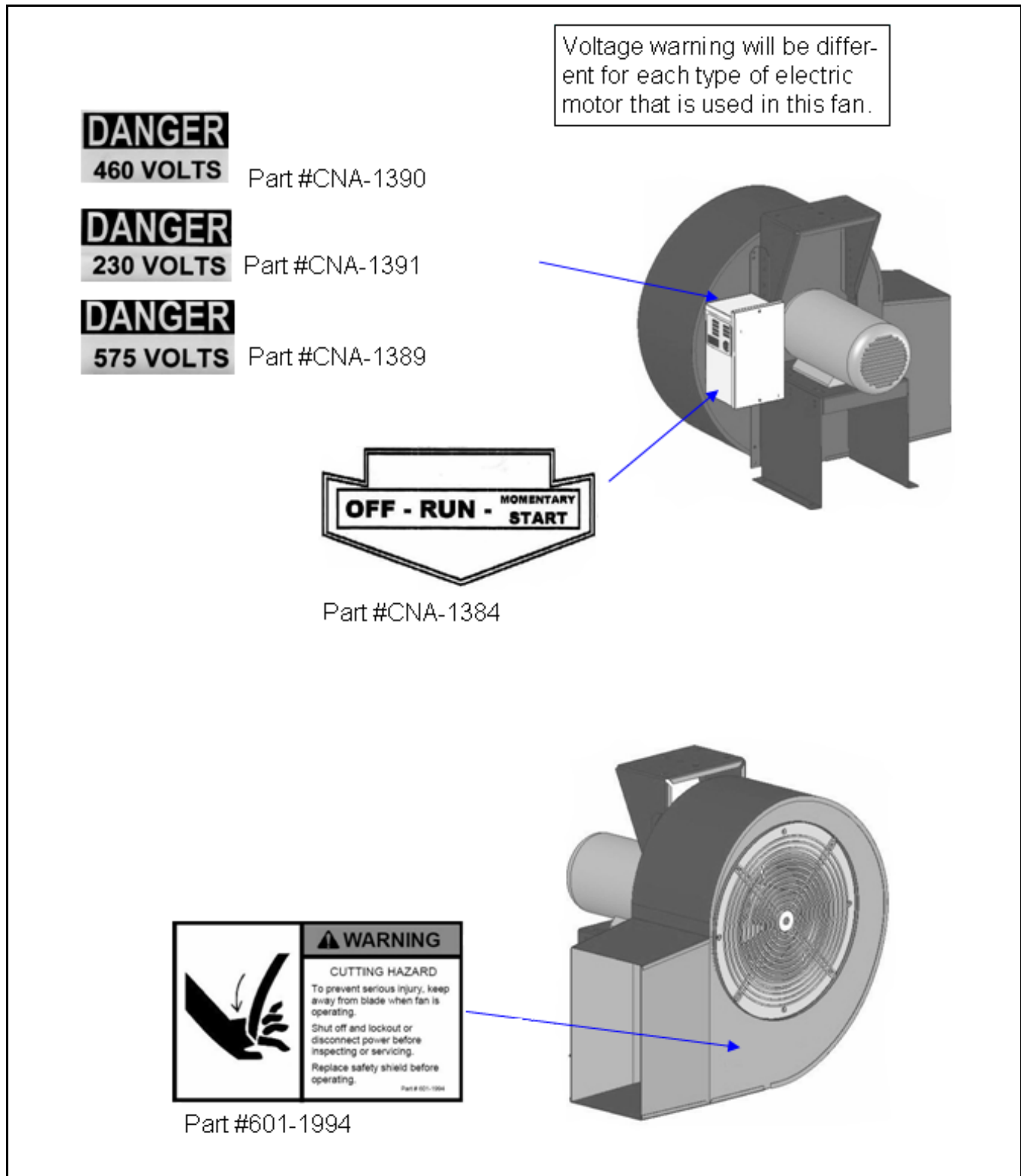

Figure 2.3 Safety Decal Locations

3. Installation

Warning: Before continuing, please reread the safety information relevant to this section in the safety section of this manual. Failure to follow the safety instructions can result in serious injury, death, or property damage.

3.1. BEFORE YOU BEGIN

Important: *All fan installation and maintenance must be done by a qualified electrician in accordance with all applicable local codes and standards.*

3.2. LOCATION & MOUNTING

➔ **Flat Bottom Bins:**

- Fan must be mounted and attached to a flat, level concrete surface.
- Ensure fan fits properly with the bin transition ducting.
- Fan must be mounted as close to the bin as possible. Leave 12" to 18" or more between the fan and bin to allow for routine servicing and inspection.
- Provide adequate drainage to protect the fan.

➔ **Hopper Bottom Bins:**

- Fan must be properly mounted on a platform or braced in a similar manner to support the fan's weight.

NOTICE

Damage will occur to the fan if not properly supported.

3.3. ELECTRIC MOTOR WIRING

- Voltage, amperage, and rpm's are located on the specification plate on the fan housing.
- A wiring diagram is located on the inside of the fan electrical box lid.
- Use a separate circuit from the distribution panel for the fan.
- Installing a time-delayed circuit breaker will allow for start up current (minimum requirement is 2.5 times the maximum running amperage on motor nameplate). Check with local electrical code for more details.
- Ensure proper gauge of cable between power source and fan unit. See Table 3.1.

NOTICE

Incorrect gauge of cable will result in low voltage supply to the motor causing premature failure.

Table 3.1 Conductor Sizes

HP	PHASE	MOTOR VOLTS	CONDUCTOR SIZES (AWG) FOR VARIOUS MOTOR TO TRANSFORMER DISTANCES				
			100 FT	150 FT	200 FT	300 FT	500 FT
5	1	230	6	4	4	2	0
	3	230	10	8	8	6	4
	3	460	12	12	12	10	8
7.5	1	230	6	4	3	1	0
	3	230	8	6	6	4	2
	3	460	12	12	12	10	8
10	3	230	6	4	4	4	1
	3	460	12	12	12	10	8
15	3	230	6	4	4	2	0
	3	460	12	10	10	8	6
20	3	230	4	2	8	1	000
	3	460	10	8	2	6	4
25	3	230	2	2	2	0	000
	3	460	8	8	6	6	4
30	3	230	2	1	1	00	0000
	3	460	8	6	6	4	2

Note: *All electrical connections and wiring must follow all applicable local codes and standards.*

4. Operation

Warning: Before continuing, please reread the safety information relevant to this section in the safety section of this manual. Failure to follow the safety instructions can result in serious injury, death, or property damage.

4.1. START-UP

1. Open bin roof vents.
2. Turn on power to fan.
- ➔ 3. For **230V models**, move the toggle switch to the START position (this is the spring-loaded or momentary position of the switch).
- ➔ 4. For **460V/575V models**, press the green START button and hold momentarily until fan starts. Fan should continue to run once green button is released.
5. If the fan does not start or if it stops running, refer to the troubleshooting section.

4.2. BREAK-IN

Although there are no operational restrictions on the machine when used for the first time, it is recommended that the following items be checked:

BEFORE STARTING:

- Read the power unit's operation manual.
- Ensure that the fan is properly attached to the grain bin and properly supported.
- During the first few minutes of operation, ensure that the unit is running properly.

AFTER OPERATING FOR 1/2 HOUR:

- Check to see if there is excessive vibration in the fan. If there is, stop the fan and consult your local dealer or the factory.

NOTICE

Continual use of a vibrating fan will cause premature failure of motor and bearings. It will also cause metal fatigue in the fan wheel assembly and fan housing.

- Check that all guards are installed and are working as intended.

AFTER OPERATING FOR 5 AND 10 HOURS:

- Check that all guards are installed and are working properly.

- Check all bolts and other hardware to ensure that everything is tight and properly positioned.

4.3. SHUTDOWN

- ➔ 1. For **230V models**, move the toggle switch to the OFF position.
- ➔ 2. For **460V/575V models**, press the red STOP button.
- 3. When shutting down the fan for extended periods of time, shut off the power at the disconnect/source to prevent any inadvertent start-up of the fan.
- 4. Close bin roof vents.

NOTICE

Heating the air going into the aeration fan will damage the fan and its components, and will void the warranty.

NOTICE

Before operating fan, ensure that the fan inlet is not obstructed or restricted in any way.

WARNING



To prevent serious injury, keep away from blade when fan is operating. Shut off and lock out or disconnect power before inspecting or servicing.

Replace safety shield before operating.

4.4. EMERGENCY STOP

FOREIGN OBJECT OBSTRUCTION

1. Immediately shut down fan and lock out power source.
2. Remove obstruction.
3. Inspect the inlet screen and fan wheel assembly for damage. Repair or replace as required.

EXCESSIVE FAN VIBRATION OR NOISE

1. Immediately shut down and lock out power source.
2. Inspect inlet for an obstruction, remove if necessary.
3. Restart fan to see if it is still vibrating excessively. If it is, immediately shut off fan and lock out power source.
4. Contact your local dealer for inspection of the fan wheel assembly.

4.5. APPLICATION REQUIREMENTS

This aeration fan must only be used for aeration and natural air drying of grain products.

A downstream heater can be added if extra drying is required.

5. Maintenance & Storage

Warning: Before continuing, please reread the safety information relevant to this section at the beginning of this manual. Failure to follow the safety instructions can result in serious injury, death, or property damage.

WARNING	
	Before performing any maintenance on this unit, shut off and lock out power source.

Note: *If required, illustrations of the fan can be found in the appendix.*

5.1. MAINTENANCE

5.1.1. CLEANING

- Check housing and fan blade periodically for debris buildup drawn in by the airstream.
- Remove safety screen and inlet to expose inner housing and fan blade.
- Clean the exposed items with soapy water and a non-abrasive brush.
- Replace all guards before using fan again.

5.1.2. SERVICING & PART REPLACEMENT

If there is any service/part replacement work required on the fan, it is important to reinstall the fan wheel assembly in exactly the same place. Failure to do so will cause premature wear, vibration, and part failure.

Ensure the edge of the inlet cone (fit into the wheel cover) covers approximately 1/2 of the lip on the face plate of the wheel.

WARNING	
	Failure to reinstall the inlet cone and screen before operating the fan may result in serious injury or death.

5.2. STORAGE

- Ensure that all foreign material is removed from the fan.
- Inspect electrical wires and repair if necessary.
- Inspect all parts and components and repair or replace as required.
- If fan must be stored outside, it should be completely covered with a tarp to ensure that foreign material and the weather will not affect the fan.
- If the fan is to be stored inside, it should be in a clean, dry location.

6. Troubleshooting

FAN RELATED PROBLEMS

1. PROBLEM: Fan does not run.

Cause	Solution
Blown fuse / tripped breaker	Replace fuse or reset breaker
No power at fan	Turn power on at source
Defective wiring/connection	Follow wiring diagram and check for broken wires and loose connections
Incorrect wire size	Refer to wire sizing charts for correct size
Defective motor	Replace if necessary
Defective magnetic starter	Check contactor for proper function

2. PROBLEM: Fan runs for a short time then shuts off.

Cause	Solution
Undersize wiring	Refer to wire sizing charts for correct size
Low line voltage at fan	If wire size is correct, call power company
Internal overload tripped	Let motor cool off then retry; if symptoms persist, check amperage draw; if high, correct, if not, thermal overload could be tripping out at incorrect temperature
Undersize wiring	Refer to wire sizing charts for correct size
Low line voltage at fan	If wire size is correct, call power company
Defective magnetic contactor	Replace contactor
Defective start/stop switch	Replace switch

3. PROBLEM: Fan makes ticking sound.

Cause	Solution
Fan impellor rubbing housing	Turn off power to fan; rotate impellor slowly to see if impellor is rubbing the housing, if so, adjust motor positioning to obtain equal clearance all around the impellor
Motor bearing defective	Replace bearing

4. PROBLEM: Fan vibrates excessively.

Cause	Solution
Fan not level	Level fan -- See Installation Section.
Dirt buildup on impellor	Clean blade
Bent motor shaft	Replace motor
Improperly mounted impellor	Position impellor correctly
Impellor out of balance	Replace or have impellor rebalanced

7. Appendix

7.1. PARTS LISTS

GRAIN GUARD FULL CENTRIFUGAL FAN—3HP

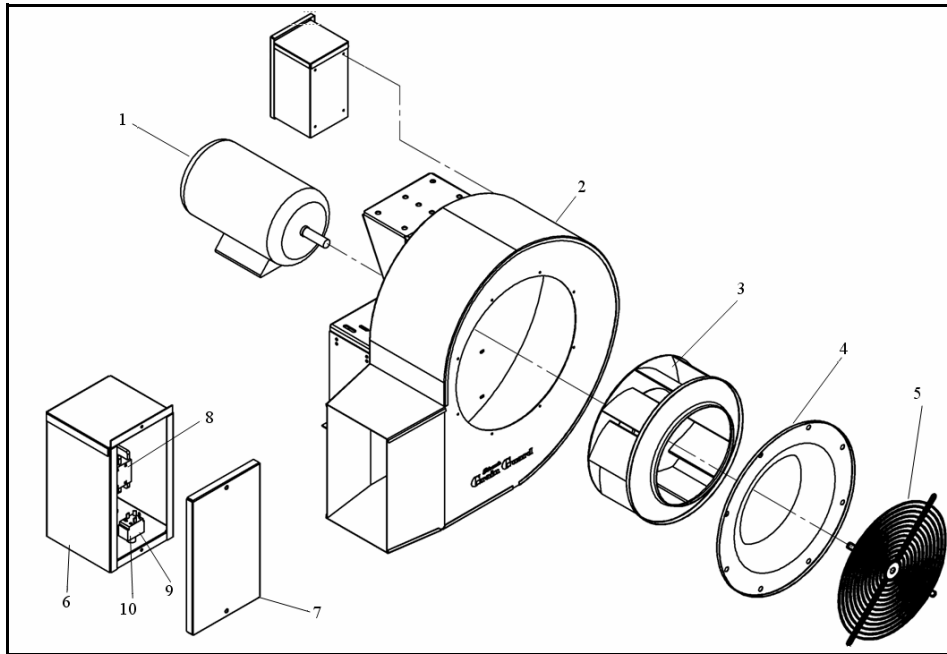

ITEM	PART NUMBER	DESCRIPTION
1	GGF-8014	MOTOR 3HP TEFC 3450RPM 1PH 230V
	GGF-8015	MOTOR 3HP TEFC 3450RPM 3PH 230/460V
	GGF-8016	MOTOR 3HP TEFC 3450RPM 3PH 575V
2	GGF-8074	3HP HOUSING
3	GGF-8064	3HP FAN WHEEL
4	GGF-8065	3HP FC INLET CONE
5	GGF-8066	INLET SCREEN 14"
6	GGF-8054	ELECTRICAL BOX
7	GGF-8063	ELECTRICAL BOX COVER
8	GGF-8041	STARTER CONTACTOR 1PH 230V
	GGF-8044	STARTER CONTACTOR 3PH 230V C/W AUX
	GGF-8045	STARTER CONTACTOR 3PH 460V C/W AUX
	GGF-8047	STARTER CONTACTOR 3PH 575V C/W AUX
9	GGF-8050	STARTER SWITCH 1PH 230V
	GGF-8052	STARTER SWITCH 3PH 460/575
10	GGF-8051	BOOT COVER 1PH 230V
	GGF-8053	BOOT COVER 3PH 460/575

GRAIN GUARD FULL CENTRIFUGAL FAN—5HP

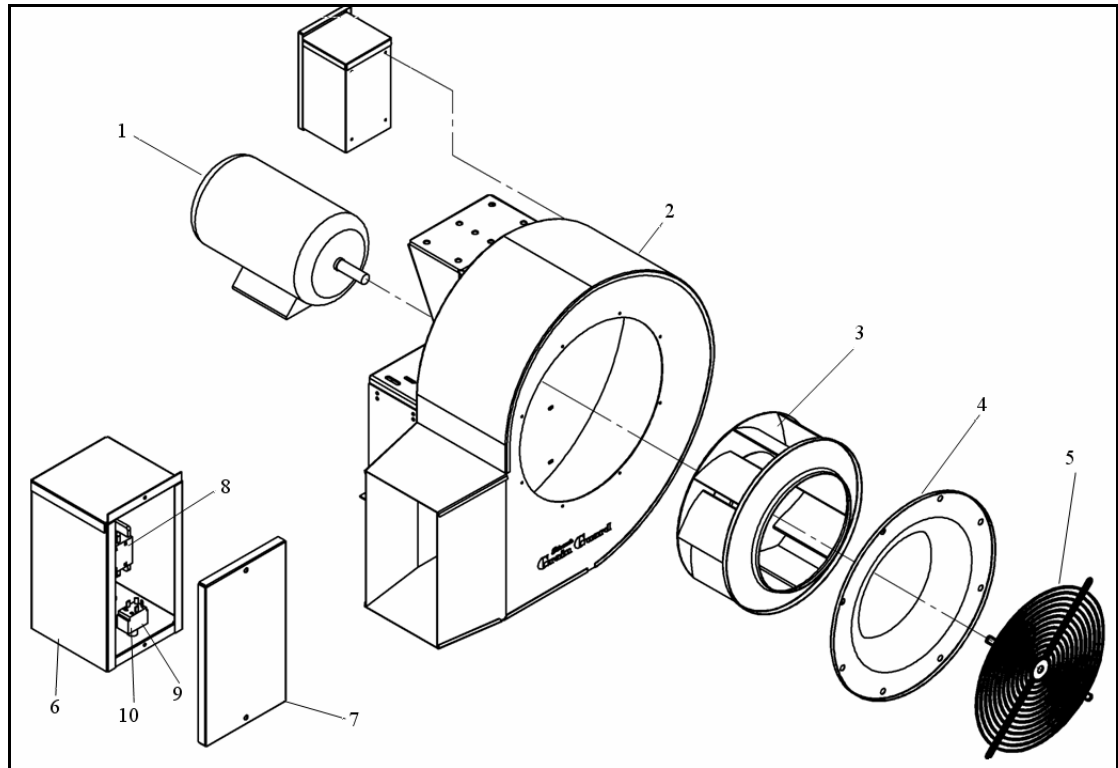

ITEM	PART NUMBER	DESCRIPTION
1	GGF-8017	MOTOR 5HP TEFC 3450RPM 1PH 230V
	GGF-8018	MOTOR 5HP TEFC 3450RPM 3PH 230/460V
	GGF-8019	MOTOR 5HP TEFC 3450RPM 3PH 575V
2	GGF-8077	5HP HOUSING
3	GGF-8068	5HP FAN WHEEL
4	GGF-8069	5HP FC INLET CONE
5	GGF-8066	INLET SCREEN 14"
6	GGF-8054	ELECTRICAL BOX
7	GGF-8063	ELECTRICAL BOX COVER
	GGF-8041	STARTER CONTACTOR 1PH 230V
8	GGF-8044	STARTER CONTACTOR 3PH 230V C/W AUX
	GGF-8045	STARTER CONTACTOR 3PH 460V C/W AUX
	GGF-8047	STARTER CONTACTOR 3PH 575V C/W AUX
9	GGF-8050	STARTER SWITCH 1PH 230V
	GGF-8052	STARTER SWITCH 3PH 460/575
10	GGF-8051	BOOT COVER 1PH 230V
	GGF-8053	BOOT COVER 3PH 460/575

GRAIN GUARD FULL CENTRIFUGAL FAN—7HP

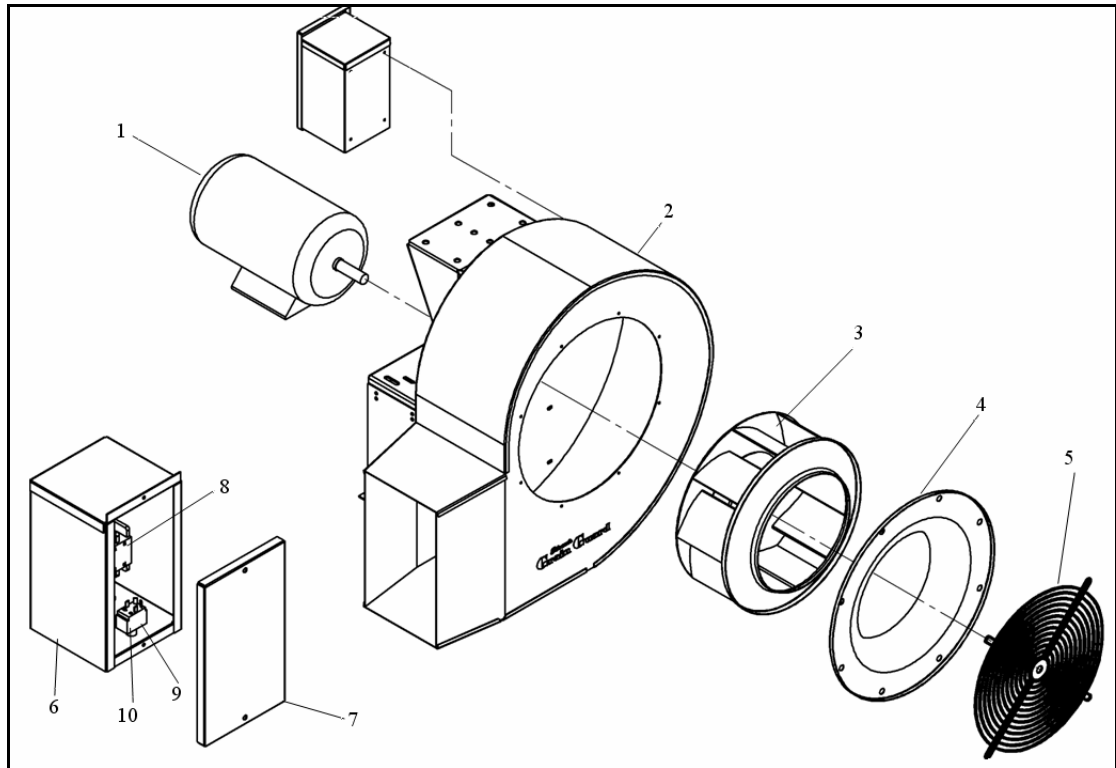

ITEM	PART NUMBER	DESCRIPTION
1	GGF-8020	MOTOR 7HP TEFC 3450RPM 1PH 230V
	GGF-8021	MOTOR 7HP TEFC 3450RPM 3PH 230/460V
	GGF-8022	MOTOR 7HP TEFC 3450RPM 3PH 575V
2	GGF-8080	7HP HOUSING
3	GGF-8070	7HP FAN WHEEL
4	GGF-8071	7HP FC INLET CONE
5	GGF-8066	INLET SCREEN 14"
6	GGF-8054	ELECTRICAL BOX
7	GGF-8063	ELECTRICAL BOX COVER
	GGF-8042	STARTER CONTACTOR 1PH 230V
	GGF-8044	STARTER CONTACTOR 3PH 230V C/W AUX
	GGF-8045	STARTER CONTACTOR 3PH 460V C/W AUX
8	GGF-8047	STARTER CONTACTOR 3PH 575V C/W AUX
	GGF-8050	STARTER SWITCH 1PH 230V
	GGF-8052	STARTER SWITCH 3PH 460/575
9	GGF-8051	BOOT COVER 1PH 230V
	GGF-8053	BOOT COVER 3PH 460/575
10		

GRAIN GUARD FULL CENTRIFUGAL FAN—10HP

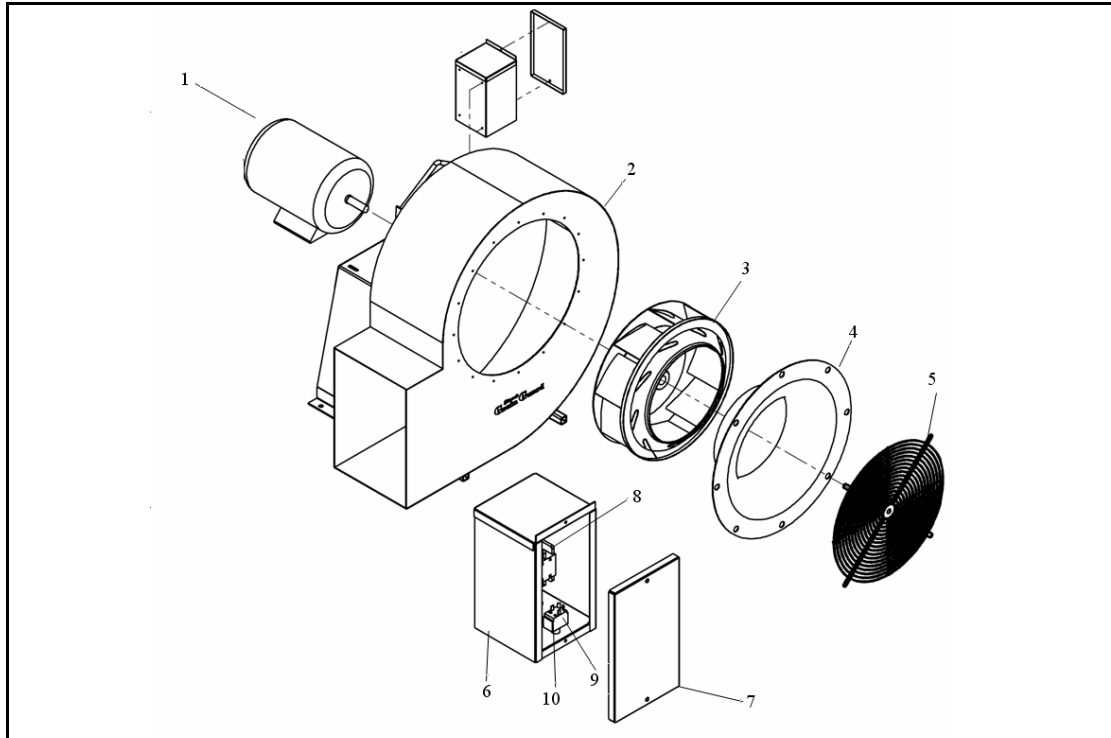

ITEM	PART NUMBER	DESCRIPTION
1	GGF-8023	MOTOR 10HP TEFC 3450RPM 1PH 230V
	GGF-8024	MOTOR 10HP TEFC 3450RPM 3PH 230/460V
	GGF-8025	MOTOR 10HP TEFC 3450RPM 3PH 575V
2	GGF-8083	10HP HOUSING
3	GGF-8072	10HP FAN WHEEL
4	GGF-8073	10HP FC INLET CONE
5	GGF-8067	INLET SCREEN 18"
6	GGF-8054	ELECTRICAL BOX
7	GGF-8063	ELECTRICAL BOX COVER
8	GGF-8043	STARTER CONTACTOR 1PH 230
	GGF-8049	STARTER CONTACTOR 3PH 230V C/W AUX
	GGF-8046	STARTER CONTACTOR 3PH 460V C/W AUX
	GGF-8048	STARTER CONTACTOR 3PH 575V C/W AUX
9	GGF-8050	STARTER SWITCH 1PH 230V
	GGF-8052	STARTER SWITCH 3PH 460/575
10	GGF-8051	BOOT COVER 1PH 230V
	GGF-8053	BOOT COVER 3PH 460/575

7.2. ELECTRICAL SCHEMATICS

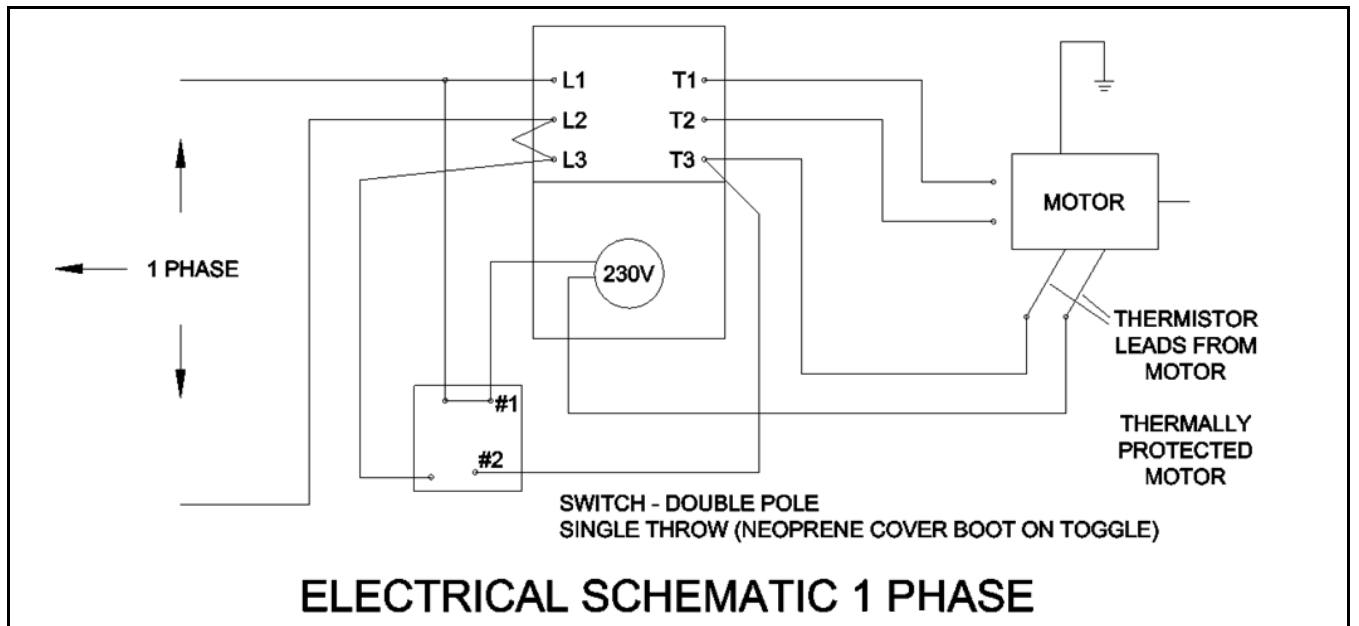
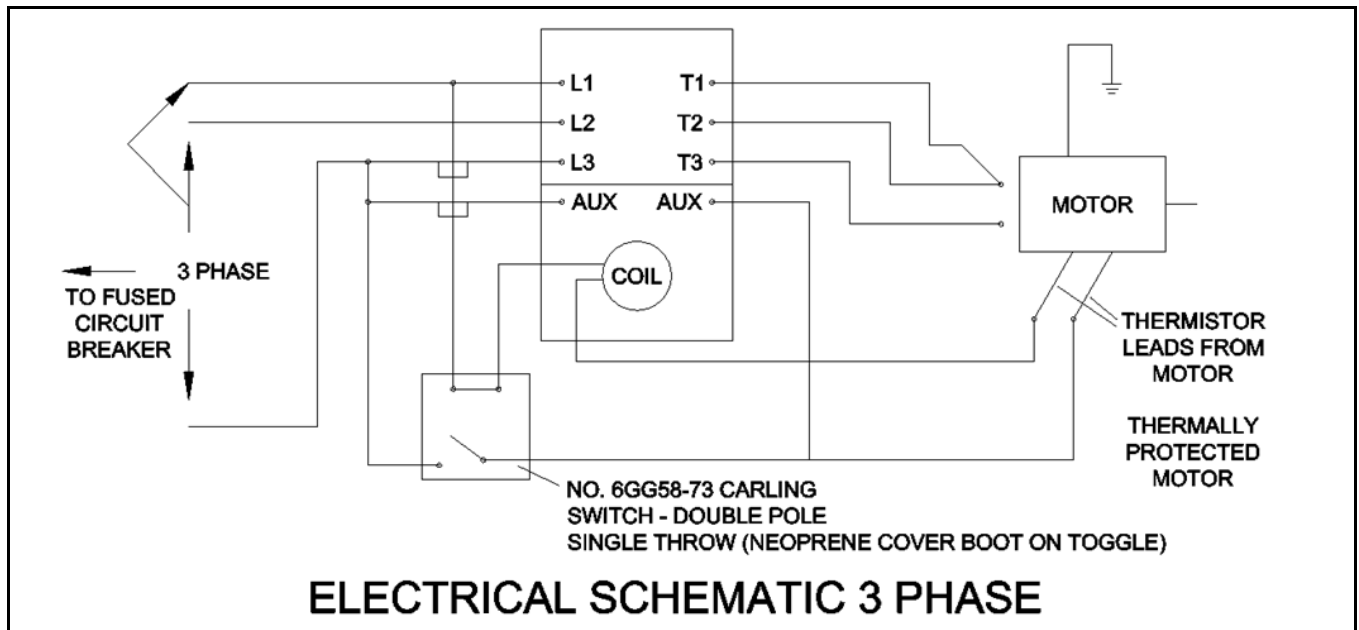

7.3. AERATION TIPS

- **WHEN CAN I BEGIN TO HARVEST?** With a complete aeration system in place, crops can be taken off at 4%–6% moisture above normal moisture content (example: wheat 18%–20%). Under warm, low, relative humidity conditions you should see 3/4–1% of drying taking place per day. This allows a 7–10 day advance on harvest time as well as more harvesting hours per day.

Note: *Natural air drying should be used as a management tool and not as a late harvest emergency drying system. Late harvest conditions are cool and damp and will result in slow natural air drying.*

- **AT WHAT TEMPERATURE DOES NATURAL AIR DRYING BEGIN?** Grain drying begins at +10°C (50°F). Anything less than +10°C means the air is too cold and can only hold a small amount of moisture; therefore, moisture movement from grain will be very slow.
- **WHEN SHOULD I START MY FAN?** In order to create a uniform drying front, the bin must be filled to the height of at least half of the bin's diameter above the aeration system. (Example: A 14' diameter bin needs to have a minimum of 7' of grain above the aeration system). The best uniform drying front can be produced by filling your bin and then turning on the fan. Turning your fan on too soon can cause uneven drying and negative results.

Relative Humidity of Air %	Wheat Equilibrium Moisture Content %		Canola Equilibrium Moisture Content %		Corn Equilibrium Moisture Content %	
	at 77°F	at 50°C	at 77°C	at 50°F	at 77°C	at 50°F
58	12	13	7.5	8.6	12.2	13.5
64	13	14	8.2	9.4	13.0	14.4
70	14	15	9.0	10.3	14.0	15.4
75	15	16	9.8	11.1	15.0	16.4
79	16	17	10.8	12.0	15.8	17.1
83	17	18	12.0	13.2	16.9	18.2
86	18	19	13.4	14.5	17.8	19.0

- **SHOULD I SHUT MY FAN OFF AT NIGHT OR WHEN IT RAINS?** NO! High moisture grain drying (16% - 20%) requires continuous air flow to prevent the drying front from crusting over and restricting airflow.
- **DOES FAN OPERATION AT NIGHT OR IN HIGH HUMIDITY CONDITIONS REVERSE THE DRYING PROCESS?** We tend to think that a fan will force moisture back into a bin in high humidity conditions. However, it is much more difficult to put moisture back into the grain than it is to take it out. In fact, grain in the bottom of the bin that may be a little over-dried would benefit from taking on a little moisture. At 19% moisture, grain that hasn't been dried will remain constant as the 86% relative humidity moisture level in the air equals the moisture in the grain.
- **IF I ADD SUPPLEMENTAL HEAT, CAN I DRY IN HIGH HUMIDITY CONDITIONS?** Adding supplemental heat (when available) to the aeration / drying process will reduce relative humidity and increase the rate of moisture movement. Therefore, a low temperature supplemental heater will increase the drying rate and reduce the drying time.
- **CAN LOW TEMPERATURE SUPPLEMENTAL HEAT CUT MY DRYING TIME WITHOUT INCREASING COSTS?** A rule of thumb relating tempera-

ture increase to relative humidity decrease is: a temperature increase of 10 °C (18°F) above outside air temperature will reduce the relative humidity by half.

Example:

10°C and 70% relative humidity
+ 10°C (increased by supplemental heat)
= 20°C and 35% relative humidity

- When low-temperature heat is added in high-humidity conditions, drying times can be reduced up to 8 days. By reducing operating time, overall costs are less than operating only the fan under these conditions.

With the average harvest period generally 30–40 days, it's comforting to know you can depend on supplemental heat—not the weather—to get the job done.

Note: *Care should be taken when operating a supplemental heater under low humidity conditions. This can cause severe over-drying at the bottom of the bin.*

- **HOW DO I KNOW WHEN MY GRAIN IS DRY?** Approximate drying chart based on a complete Aeration System:

<u>Approximate Condition</u>	<u>Approximate Drying %</u>
Ideal warm days / dry conditions	1% per day
Warm days & cool nights	1/2% per day
Cool days & cool damp nights	1/4% per day
Cold days & cold nights	0% per day
Warm days & cool nights (supplemental heat added)	3/4% per day

Note: *If you add 1 or 2 loads of grain at 18% moisture into the bin, assume the bin to be at 18% average moisture—don't reduce the average if some loads are at a lower percentage.*

Note: *Do not count the first day in the drying process; it takes 14–16 hours for the bin to equalize its temperature.*

- **WHEN SHOULD I SHUT MY FAN OFF?** When bin samples show the grain is dry, turn off the fan.
- **WHAT CAN I DO WHEN THE AIR TEMPERATURE DOES NOT REACH +10°C? (late October - early November)**

There are a couple of options available at this point:

- a. You can dry the grain in a grain dryer and then cool it down with the Aeration system to maximize the grain dryer daily output.
- b. You can wait until the outside air temperature falls to -5 to -10°C and then run the fan for 24–48 hours to cool the entire grain mass to a storage state (see charts on next page). Once spring conditions return, you can resume the grain aeration / drying process.

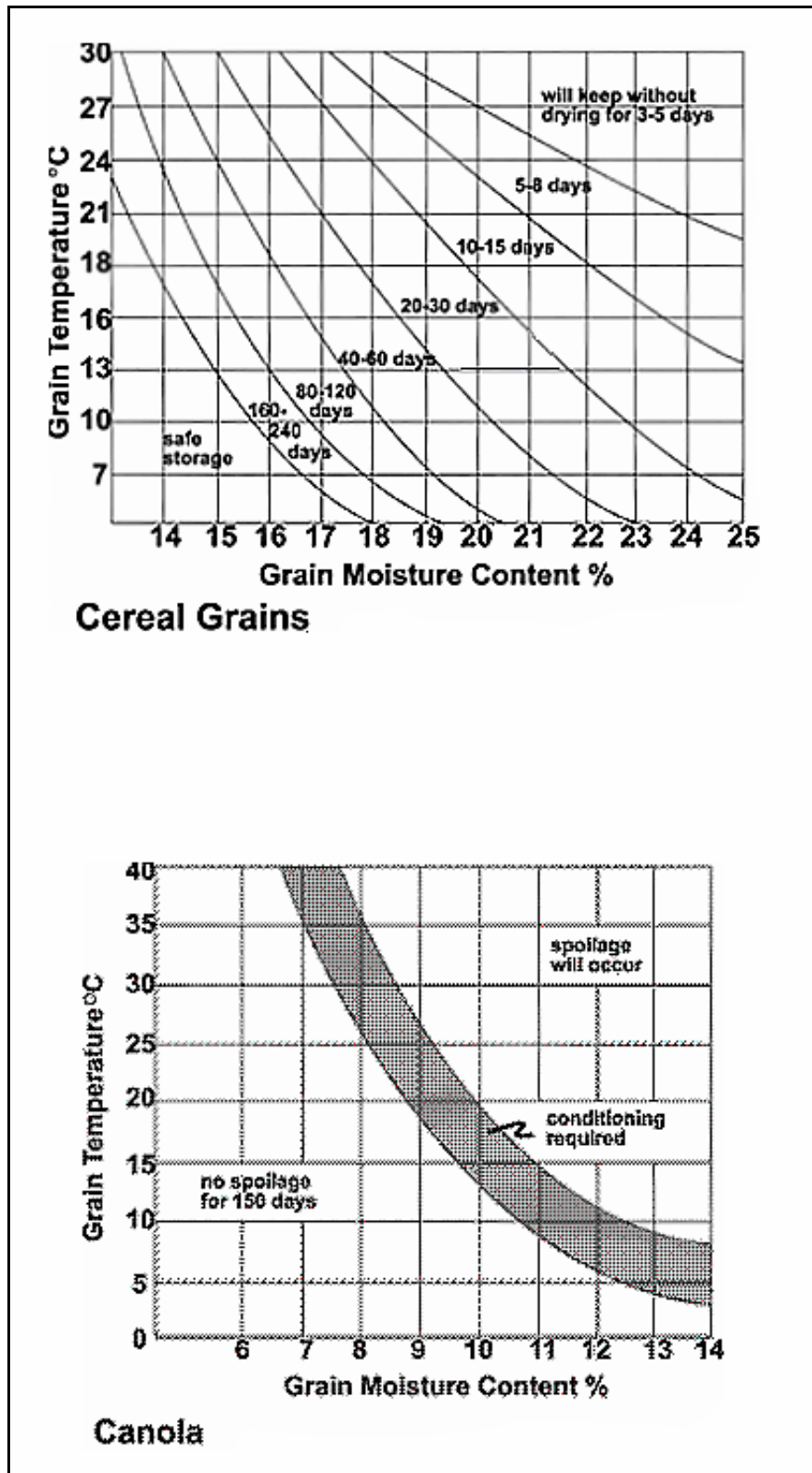

Figure 7.1 Grain Drying Charts

WARRANTY

Except as expressly provided in this agreement, Edwards (hereinafter called the Manufacturer) excludes all express or implied warranties, conditions, and obligations of the Manufacturer, whether statutory or otherwise, concerning the quality of the units or their fitness for any purpose.

Under no circumstances will the Manufacturer be liable for any kind of special, consequential, indirect, or incidental damages resulting from the use of its products, nor shall the Manufacturer's liability ever exceed the selling price of the product.

Edwards Group warrants their products as follows:

1. Goods free from defect:
 - a. The unit shall be free from defects in materials and workmanship and shall operate properly in accordance with industry standards when employed in normal usage, provided the unit has been properly installed for a period of: three (3) years from the original date of purchase.
2. The warranty does not include:
 - a. Routine replacement of parts due to normal wear and tear arising from use.
 - b. Any defect attributable in whole or in part to misuse or improper installation.
 - c. Any damage or defect attributable to repair of the unit outside the Manufacturer's facilities or those of an authorized dealer, or the installation of unapproved parts on the unit in the Manufacturer's judgment to affect its performance or reliability, or which has been subject to misuse, negligence, or accident.
 - d. Any damage attributable to accident or to lightning, power surge, brownout, leaking, damage, or connection to a power source having a greater rating than that specified in the unit specifications.
3. Repair or Replacement

Where any part of the unit fails during normal usage during the warranty period specified, the Manufacturer, or authorized dealer of the Manufacturer, shall repair or replace the defective part of the unit with a new or factory reconditioned part, such replacement or repair to be made without charge for parts or labor, F.O.B. the Manufacturer.

4. Warranties shall not apply to any product made by the Manufacturer that has not been operated in accordance with the Manufacturer's printed instructions or shall have been operated beyond the rated capacity of the product or a use not intended.
5. The Manufacturer reserves the right to make design or specification changes at any time, without contingent obligation to purchasers of products already sold.

WARRANTY VOID IF NOT REGISTERED



Edwards Group is a Division of Ag Growth Industries LP

Part of the Ag Growth International Inc. Group

P.O. Box 1600

Lethbridge, Alberta, Canada T1J 4K3

Phone: (403) 320-5585

Fax: (403) 320-5668

Toll Free: (800) 565-2840 (Canada & USA)

Website: www.edwardsgroup.ca

© Ag Growth Industries Limited Partnership 2010