

WESTEEL 





CRADLE TANKS

AFFORDABLE ULC LISTED STORAGE OPTIONS



EXCELLENCE IN STEEL FABRICATION FOR MORE THAN A CENTURY



Today, environmental and safety concerns demand that special care be taken when selecting liquid storage solutions, especially when it comes to the storage of petroleum products. That's why so many choose Westeel. As Canada's leading manufacturer of liquid storage products, Westeel offers the widest selection of tanks and tank options to meet the needs of almost any application. Westeel offers a fully customizable product line. Moreover, all of our products are professionally engineered to not only meet or exceed all government standards but are also competitive products in their respective categories – exactly what you would expect from a brand that has stood for excellence in steel fabrication for more than a century, and all backed with some of the best warranties in the business.

STATE-OF-THE-ART MANUFACTURING
 Westeel's commitment to innovative engineering and application of the latest technologies has made it a leader in the steel products manufacturing industry in North America. As part of that commitment, Westeel invests in the latest manufacturing techniques and equipment including computer assisted cutting and welding. The result is precision manufactured products that fit together perfectly, last longer, and perform as expected. One of the most important factors in determining the longevity of any tank is the quality of its paint finish. That's why Westeel employs state-of-the-art paint application processes that ensures the finish provides superior protection from weather and corrosion. This results in a highly durable chemical and scratch resistant finishes suitable for the toughest environments. Westeel's petroleum storage manufacturing facilities are dedicated to tank fabrication only and are certified ISO-9001:2008.

CRADLE TANKS HORIZONTAL SINGLE WALL AST From 1,300 to 4,500 Litres

Westeel's Single Wall Above Ground Storage Tank (AST) has been an excellent alternative to overhead tanks for many years coast-to-coast. It is engineered to provide user friendly storage options for flammable and combustible liquids for a long list of applications. Easy to use and install, its single wall storage system complete with low welded cradles and additional pump fitting makes fluid transfer options simple.

Cradle Tanks Horizontal Single Wall AST ULC S601 Specifications

MODEL NUMBER	CAPACITY		DIAMETER (D)		LENGTH (L)		WEIGHT	
	Imp gal	L	in	mm	in	mm	lb	kg
CSW1300	300	1364	38	965	73	1854	362	164
CSW2200	500	2273	50	1270	73	1854	494	223
CSW4500	1000	4546	50	1270	144	3660	826	374

Note: Westeel also offers a full line of customizable tanks in a variety of capacities. Please contact our customer service department for full details. Note that all capacities shown in this brochure are estimates.

FUEL-VAULT®

DUAL WALL HORIZONTAL PETROLEUM STORAGE TANKS



THE EASIEST AND MOST ENVIRONMENTALLY SAFE WAY TO STORE FLAMMABLE OR COMBUSTIBLE LIQUIDS.

From 1,300 to 142,000 litres

Westeel's Fuel-Vault Double Wall Integral Contained Above Ground Storage Tanks are available in many different sizes, and with numerous options and multi compartment configurations, they can also be customized to the specific needs of the customer.

TYPICAL APPLICATIONS

- Petroleum retailing facilities ▪ Petroleum refuelling facilities and fleet ▪ Aviation ▪ Stand-by generators ▪ Agricultural ▪ Industrial ▪ Oil and gas ▪ Forestry ▪ Mining ▪ Marine ▪ Municipal ▪ Recreational ▪ Rental applications

ACCORDANCE COMPLIANCE

- CAN/ULC – S601 Current Version ▪ National/Provincial Fire Code Compliant ▪ Environmental Farm Plan Compliant ▪ Environmental Resources Conservation Board ▪ Directive 55 Compliant ▪ CWB ▪ ISO

IMPORTANT FEATURES (Varies by tank capacity)

- Durable steel construction ▪ Secondary shell provides a minimum 100% containment ▪ Large mouth spill box with fill, gauge, and drain openings with a lockable weatherproof cover for tanks larger than 11,000L ▪ Weather and corrosion resistant exterior coating ▪ Standard wide saddles ▪ Interstitial space inspection port to help identify any possible fluid release ▪ Emergency pressure surge vent ▪ Gauge stick/gauge chart and holder for confirming volume

included with tanks larger than 11,000L ▪ Heavy-duty lifting lugs for off-loading and positioning ease ▪ Canstrut tabs on both heads to attach equipment options

OPTIONAL EQUIPMENT (Varies by tank capacity)

- Overfill prevention devices ▪ Anti siphon prevention

Fuel-Vault® Horizontal Specifications (tank only)

MODEL NUMBER	CAPACITY		WIDTH		LENGTH		WEIGHT	
	gal	l	in	mm	in	mm	lb	kg
HFV1300	300	1364	38.00	965	73.0	1854	695	316
HFV2250	500	2270	50.00	1270	73.0	1854	954	434
HFV4500	1000	4546	50.00	1270	145.0	3680	1560	709
HFV8500	1886	8575	63.00	1600	168.0	4265	3000	1360
HFV11000	2425	11026	63.00	1600	215.9	5484	3550	1610
HFV15000	3289	14952	93.50	2375	132.9	3375	6000	2727
HFV25000	5344	24295	93.50	2375	215.9	5484	8500	3863
HFV35000	7610	34870	93.50	2375	309.8	7871	11000	5000
HFV50000	10859	49376	117.90	2997	275.5	6998	15000	6818
HFV65000	14132	64245	117.90	2997	358.5	9107	18500	8390
HFV75000	16457	74812	117.90	2997	417.5	10605	21000	9545
HFV80000	17363	78932	117.90	2997	440.5	11189	24500	11150
HFV91500	20133	91524	125.00	3175	455.1	11560	27000	12217
HFV100000	22143	100660	125.00	3175	500.5	12714	29000	13180
HFV120000	26836	121996	137.75	3500	499.2	12680	37000	16818

Kit Information for Fuel-Vault® Horizontal Tanks

(The Fuel-Vault tank capacities listed have the following pump packages and skid packages available.)

TANK CAPACITY	TANK PACKAGES	PUMP	SKID
2300L, 4500L, 8500L, 11000L	STANDARD DUTY	Up to 20 GPM regular flow pump meter, 20' ¾" arctic hose, ¾" auto nozzle, level gauge	Regular skid
	HEAVY DUTY	Up to 30 GPM high flow pump meter, 20' 1" arctic hose, auto nozzle, level gauge	Heavy-duty skid (forklift pockets and corner bollards)
15000L, 25000L, 35000L	HEAVY DUTY	¾ HP submersible pump, 40 GPM with meter and 1" arctic hose, 1" auto nozzle with safety shut off, drip pot, hose retractor, filter, level gauge and factory wired explosion proof switch - installed	Heavy duty extended skid comes with extended grated platform on discharge end and corner protective bollards
50000L, 65000L, 75000L	HEAVY DUTY	¾ HP submersible pump, 40 GPM with meter, filter, 20' ¾" arctic hose with ¾" auto nozzle and safety shut off, 20' 1 ¼" arctic hose with 1 ½" auto nozzle and safety shut off, drip pot, hose retractor, level gauge, and factory wired to explosion proof switch - installed	Heavy duty extended skid comes with extended grated platform on discharge end and corner protective bollards

Single and dual hose packages available on all tanks 15000L to 75000L capacity.

1,300L to 4,500L Tank Features

01. Double wall Fuel-Vault
02. Skid (Heavy duty model shown)
03. Automatic nozzle
04. Nozzle holder
05. UCL S601 (Integral Contained) nameplate
06. Mechanical meter (litres)
07. Fuel filter
08. 115V AC fuel pump
09. Hose retractor with mast
10. Arctic hose
11. Fill port with vented cap
12. Level gauge (ships loose)
13. Vent (ships loose)
14. Containment inspection port
15. Gauge stick (ships loose)

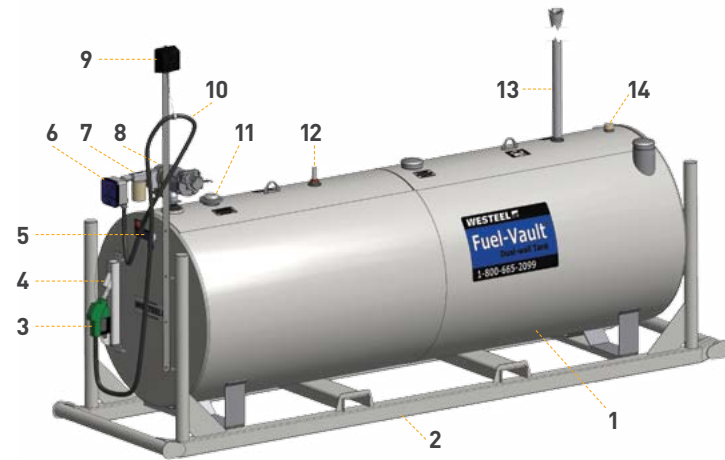

8,500L to 11,000L Tank Features

01. Double wall Fuel-Vault
02. Skid (Heavy duty model shown)
03. Step Package
04. Automatic nozzle
05. Nozzle holder
06. UCL S601 (Integral Contained) nameplate
07. Mechanical meter (litres)
08. Fuel filter
09. 115V AC fuel pump
10. Arctic hose
11. Hose retractor with mast
12. Vent (ships loose)
13. Spare fitting
14. Level gauge (ships loose)
15. Containment Inspection port
16. Fill port with vented cap
17. Gauge stick (ships loose)



15,000L to 75,000L Tank Features

01. Double wall Fuel-Vault
02. Head mount ladder
03. Containment inspection port
04. Gauge stick (ships loose)
05. Spillbox with internal dip port and spare fitting
06. Vent (ships loose)
07. Spare fitting
08. Heavy duty skid with bollards and platform extension
09. Spare fitting
10. UCL S601 (Integral Contained) nameplate
11. Remote top fill, filling camlock and overfill valve
12. 220V AC submersible turbine pump
13. Anti-siphon line
14. Single or dual hose retractor with mast
15. Arctic hose and automatic nozzle
16. Nozzle holder / drip pot
17. Secondary arctic hose and automatic nozzle (where equipped)
18. Secondary nozzle holder / drip pot
19. Explosion proof 220V AC pump switch
20. Ball valve
21. Fuel filter
22. Mechanical meter (litres)

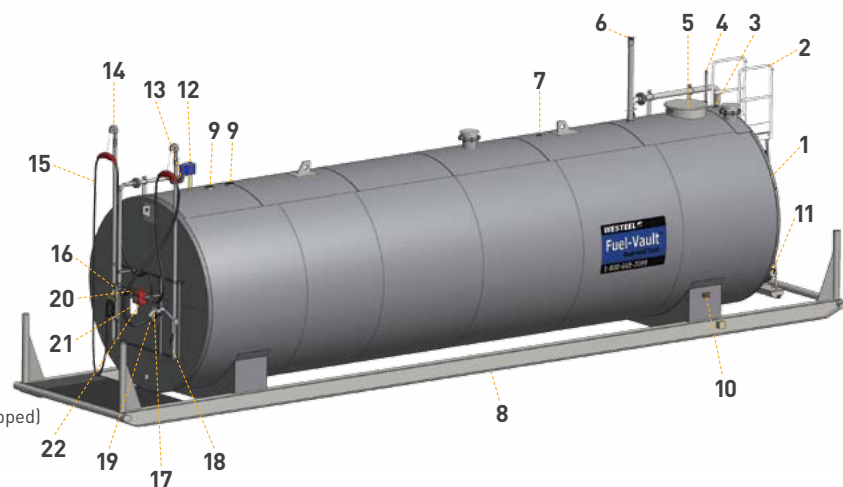

1,300L to 4,500
8,500L to 11,000L
15,000L to 75,000L

Note: Lift lugs are not to be used to move tank while containing product. Tank must not be elevated >300mm as per Fire Code requirements.

FUEL-VAULT®

VERTICAL SINGLE & DUAL WALL TANKS FOR LARGE VOLUME/REDUCED FOOTPRINT LIQUID STORAGE



Vertical Single Wall Tank

Fuel-Vault® Vertical Specifications

MODEL NUMBER	CAPACITY		WIDTH		HEIGHT		WEIGHT	
	gal	l	in	mm	in	mm	lb	kg
VFV2500	551	2500	66	1676	64	1626	1400	635
VFV5000	1100	4995	84	2134	80	2032	2500	1134
VFV9000	2015	9150	84	2134	126	3200	3400	1543
VFV15000	3414	15500	102	2591	134	3396	5700	2586
VFV24000	5264	23900	115	2921	159	4038	7300	3312
VFV35000	7731	35100	139	3531	161	4101	12000	5445
VFV50000	10903	49500	139	3531	221	5612	15000	6806
VFV70000	15352	69700	139	3531	304	7733	20000	9074
VFV90000	19163	87000	139	3531	376	9549	24000	10889
VFV104000	22930	104100	139	3531	447	11352	28000	12704
VFV125000	27445	124600	139	3531	532	13511	32000	14519
VFV140000	30639	139100	139	3531	592	15035	35000	15880
VFV142000	31278	142000	139	3531	604	15340	36000	16334

Vertical Single Wall Tanks

Westeel offers Vertical Single Wall Tanks with capacities ranging from 15,000L to 235,000L. Each tank is custom designed to the specific requirements of the location.

ROAD-VAULT®

MOBILE PETROLEUM TANKS



LEADING EDGE INNOVATION IN MOBILE PETROLEUM TRANSPORT.

From 285 to 1,030 litres

Westeel's Road-Vault product line provides leading edge innovation in mobile petroleum transport. Easy to use and install, they come complete with all of the standard features your mobile refuelling application needs to ensure safe transport practices.

TYPICAL INDUSTRY APPLICATIONS

▪ Agricultural, construction, aviation, industrial, oil and gas, forestry, mining, marine, recreational, as well as rental applications

ACCORDANCE COMPLIANCE

CAN/CGSB-43.146 (Mobile IBC)

Key Benefits

SINGLE WALL FLAT TOP ROAD-VAULT® TANKS

▪ Newly redesigned single wall Road-Vault line from Westeel with three profiles: small, medium and large
 ▪ Medium and large models have embossed ends for added strength
 ▪ 285L, 290L, 450L and 545L models have a low-profile design that can sit in the back of a pickup truck without obstructing the view out of the rear window
 ▪ 285L model also fits between the wheel wells and back window on a short box pickup, allowing the user to accommodate both the fuel tank and most fifth wheel hitches
 ▪ Circular pump mounts on all models eliminate coating issues
 ▪ J-bolt tie down on all models allows for ease of installation and removal
 ▪ Optional lifting lugs can be used to move the tank with fuel inside
 ▪ Three standard fittings on all models, with optional extra fittings available
 ▪ Integral baffle system on 830L, 680L, 545L, 450L and 285L models increases structural rigidity and decreases fuel sloshing

SINGLE WALL L-SHAPED ROAD-VAULT® TANKS

▪ Designed to fit most truck cargo boxes and cross bed tool storage containers
 ▪ Consists of a heavy gauge tank shell and strong ends to prevent deflection under load
 ▪ Heavy-duty lifting lugs, end handles and tie downs supplied for easy installation and safe secure tank placement

EXTRA LARGE SINGLE WALL FLAT TOP ROAD-VAULT® TANKS

▪ Consists of a heavy gauge tank shell and strong ends to prevent deflection under load
 ▪ Embossed bottoms provide skids for easy loading, positioning and air circulation around the tank to combat corrosion
 ▪ Internal baffles for ultimate tank stability and strength

TRAVELER ROAD-VAULT® TANKS

▪ Double wall protection for your peace of mind
 ▪ Low profile allows for greater rear window visibility without compromising capacity
 ▪ Secondary inspection port
 ▪ Fusible link emergency vent

Single Wall L-Shaped Road-Vault Tank



Single Wall Flat Top Road-Vault Tank



Double Wall Traveler Road-Vault Tank



ROAD-VAULT®



Single Wall Flat Top Road-Vault® Specifications

MODEL NUMBER	CAPACITY		MAX. FILL CAPACITY*		WIDTH		LENGTH		HEIGHT		DRY WEIGHT		WET WEIGHT	
	Imp gal	l	Imp gal	l	in	mm	in	mm	in	mm	lb	kg	lb	kg
Small														
RV285	63	285	58	266	16.2	412	54.5	1385	20.7	526	165	75	702	318
Medium														
RV290	64	290	60	275	29.3	745	30.7	780	20.7	526	140	64	686	311
RV450	99	450	95	435	29.3	745	47.4	1205	20.7	526	220	100	1067	484
RV545	121	545	114	520	29.3	745	58.5	1485	20.7	526	250	113	1286	583
Large														
RV680	150	680	144	655	29.3	745	47.4	1205	30.9	785	295	134	1576	715
RV830	183	830	172	785	29.3	745	58.5	1485	30.9	785	320	145	1883	854

Wet weight calculated at 95% tank capacity & specific gravity = 0.9 (Diesel)

*TC Codes limit the maximum fill capacity of a Mobile IBC to be 95% of the tank capacity

Optional lifting lugs and ratchet straps available on some models.

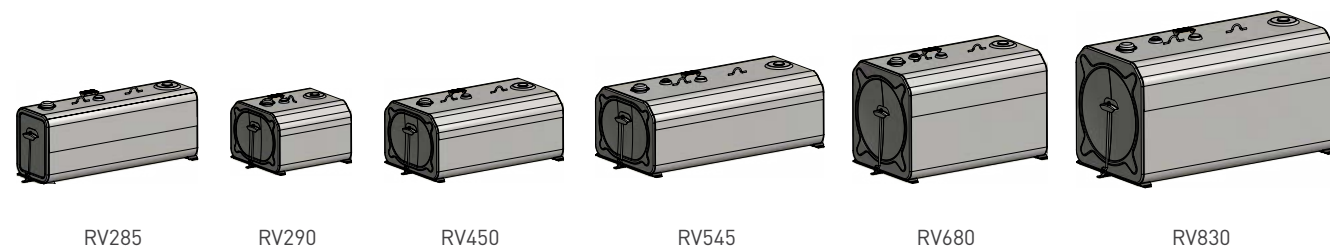

Extra Large Single Wall Flat Top Road-Vault® Specifications

MODEL NUMBER	CAPACITY		MAX. FILL CAPACITY*		WIDTH		LENGTH		HEIGHT		WEIGHT	
	Imp gal	l	Imp gal	l	in	mm	in	mm	in	mm	lb	kg
RVFT1032	227	1032	215	980	29	737	68	1727	33	838	426	193

*TC Codes limit the maximum fill capacity of a Mobile IBC to be 95% of the tank capacity

Single Wall L-Shaped Road-Vault® Specifications

MODEL NUMBER	CAPACITY		MAX. FILL CAPACITY*		WIDTH			LENGTH		HEIGHT			WEIGHT							
	Imp gal	l	Imp gal	l	W1	W2	W3	L1	L2	H1	H2	H3	lb	kg						
RVL339	75	339	71	322	29	740	18	457	11	279	48	1220	25	636	16	406	9	229	220	100
RVL419	92	419	87	398	29	740	18	457	11	279	60	1524	25	636	16	406	9	229	259	118

*TC Codes limit the maximum fill capacity of a Mobile IBC to be 95% of the tank capacity

Double Wall Traveler Road-Vault® Specifications

MODEL NUMBER	CAPACITY		MAX. FILL CAPACITY*		WIDTH		LENGTH		HEIGHT		WEIGHT	
	Imp gal	l	Imp gal	l	in	mm	in	mm	in	mm	lb	kg
RVT454	100	454	95	431	29.25	743	49.5	1257	20.5	521	405	183
RVT659	145	659	137	626	29.25	743	49.5	1257	30.5	775	510	231
RVT818	180	818	171	777	29.25	743	61.5	1562	30.5	775	598	271

*TC Codes limit the maximum fill capacity of a Mobile IBC to be 95% of the tank capacity

Westeel also manufactures mobile farm tanks (non-code). Please visit westeel.com for more information.

LEADING EDGE INNOVATION IN MOBILE PETROLEUM STORAGE.

From 2,090 to 4,500 litres

Westeel's Road-Vault Single and Double Wall ASTs are engineered to provide safe mobile transportation of flammable or combustible liquids compliant with Transport Canada (TC) regulations. Easy to use and install, they come complete with all of the standard features your mobile refuelling application needs to ensure safe transport practices.

ACCORDANCE COMPLIANCE

= CAN/CGSB - 43.146

Road-Vault® Mobile Service Specifications

MODEL NUMBER	CAPACITY		MAX. FILL CAPACITY*		WIDTH		LENGTH		HEIGHT		WEIGHT	
	Imp gal	l	Imp gal	l	in	mm	in	mm	in	mm	lb	kg
RVMS-DW460	460	2091	437	1986	48.8	1265	73	1854	54.2	1377	1208	548
RVMS-SW500	500	2273	475	2159	49.8	1265	73	1854	54.2	1377	761	346
RVMS-DW950	950	4320	902	4104	50.0	1270	145	3680	54.2	1377	2512	1140
RVMS-SW990	990	4500	940	4275	50.0	1270	145	3680	54.2	1377	2424	1100

*TC Codes limit the maximum fill capacity of a Mobile IBC to be 95% of the tank capacity

OPTI-VAULT

ECONOMICAL DUAL WALL HORIZONTAL
PETROLEUM STORAGE TANKS



AN ECONOMICAL AND ENVIRONMENTALLY SAFE WAY TO STORE FLAMMABLE OR COMBUSTIBLE LIQUIDS.

From 2,250 to 4,500 litres

Westeel's Opti-Vault Double Wall Integral Contained Above Ground Storage Tanks are available in two sizes and can be packaged with regular duty skids and economical pump packages.

TYPICAL APPLICATIONS

Stand-by generators ▪ Agriculture ▪ Golf Course Maintenance ▪ Municipal ▪ Recreational ▪ Small fleet refueling

ACCORDANCE COMPLIANCE

CAN/ULC S601 Current Version ▪ National/Provincial Fire Code Compliant ▪ Environmental Resources Conservation Board
▪ Directive 55 Compliant ▪ CWB ▪ ISO

IMPORTANT FEATURES

Durable steel construction ▪ Secondary shell provides a minimum 100% containment ▪ Weather and corrosion resistant exterior powder coat finish ▪ Saddles ▪ Interstitial space inspection port ▪ Emergency pressure surge vent ▪ Lifting lugs

OPTIONAL EQUIPMENT

Regular duty skids ▪ Economical pump packages

Opti-Vault Horizontal Double Wall Specifications

MODEL NUMBER	CAPACITY		WIDTH		LENGTH		WEIGHT	
	gal	l	in	mm	in	mm	lb	kg
264904E	500	2270	50.00	1270	73.0	1854	941	427
264905E	1000	4546	50.00	1270	145.0	3680	1560	709

RECYCOIL®

USED OIL STORAGE
TANKS



TRUSTED FOR WORRY-FREE PROTECTION.

From 1,135 to 5,000 litres

Recycoil used oil storage tanks are the easiest and safest way to store used oil and hazardous liquid waste. Trust them for worry-free protection against costly and environmentally damaging leaks or ruptures. ULC certified and national fire code compliant. Recycoil tanks are specifically engineered to meet or exceed all national environmental and hazardous waste regulations as well as provide years of worry-free service.

ACCORDANCE COMPLIANCE

▪ Recycoil assembly labelled to ULC S652

Recycoil® Rectangular Contained Tanks for Combustible Liquid ULC S652 Specifications

MODEL NUMBER	CAPACITY			WIDTH		LENGTH		HEIGHT		WEIGHT	
	U.S. gal	imp gal	l	in	mm	in	mm	in	mm	lb	kg
R1100	300	250	1135	48.5	1231	74.4	1891	36.1	917	710	322
R2400	634	528	2400	57.6	1464	99.8	2535	42.6	1082	1210	549
R2499	660	550	2499	40.2	1020	79.7	2025	66.9	1699	1180	535
R5000	1320	1099	5000	57.8	1469	120.8	3068	78.2	1986	2650	1202

Recycoil® Cylindrical Contained Tanks for Combustible Liquid ULC S652 Specifications

MODEL NUMBER	CAPACITY		WIDTH		LENGTH		WEIGHT	
	gal	l	in	mm	in	mm	lb	kg
HFV1300	300	1364	38	965	73	1854	695	316
HFV2250	500	2270	50	1270	73	1854	954	434

S601 and S602-compliant Rectangular Fuel-Vault tanks for flammable and combustible liquids are also available. Please visit westeel.com for more information.

FUEL OIL TANKS

SINGLE & DUAL WALL TANKS
FOR PETROLEUM STORAGE



ENGINEERED FOR ENVIRONMENTALLY SAFE HANDLING.

From 280 to 1,135 litres

Engineered to provide environmentally safe handling for heating/generator fuels or lubricant oil storage, Westeel's line of fuel oil above ground storage tanks come in an affordable single wall design, as well as a 110% secondary containment double wall design.

Fuel Oil Double Wall AST ULC S602 Specifications

MODEL NUMBER	CAPACITY		WIDTH		LENGTH		HEIGHT		WEIGHT	
	gal	l	in	mm	in	mm	in	mm	lb	kg
ULC-FOSC-60	62	283	23	585	24	610	47	1185	247	112
ULC-FOSC-100	102	465	23	585	36	915	47	1185	319	145
ULC-FOSC-150	152	693	23	585	48	1219	47	1185	368	167
ULC-FOSC-200	206	936	23	585	68	1720	47	1185	478	218
ULC-FOSC-250	249	1135	23	585	82	2080	47	1185	558	253

Fuel Oil Single Wall AST ULC S602 Specifications

MODEL NUMBER	CAPACITY		WIDTH		LENGTH		HEIGHT		WEIGHT	
	gal	l	in	mm	in	mm	in	mm	lb	kg
ULC-FOSW-60	62	283	23	585	18	457	47	1185	122	55
ULC-FOSW-100	102	465	23	585	30	750	47	1185	152	69
ULC-FOSW-150	152	693	23	585	48	1219	47	1185	199	90
ULC-FOSW-200	206	936	23	585	60	1511	47	1185	290	132
ULC-FOSW-250	249	1135	23	585	72	1829	47	1185	333	151

ACCESSORIES



Fill and pressure vent cap



Defender closed



Fluid meter and pump



Defender open

A FULL LINE OF ACCESSORIES.

Westeel offers a wide variety of accessories suited to a diverse range of applications. As well, each of our products is fully supported by our warranty – we protect your investment as well as your resources. Trust Westeel when storing what matters most.

ELECTRIC FLUID TRANSFER PUMPS

Fluid Transfer Electric Pumps are your best value when you need safe and fast fluid transfer from your AST to your equipment. With flow rates starting at 68 litres per minute (with meter attached), Westeel has all your cold weather pumping requirements covered.

PUMP PROTECTION

Defend your pump from theft, vandalism and elemental damage with the Defender Pump Guard - fits most GPI and Fill-Rite pumps.

FLUID METERING

Cold Weather AST fluid meters are a great addition to your existing gravity flow, 12V or electric pump and let you accurately track your fuel usage to better control operational costs.

FILL AND PRESSURE VENT CAPS

Preserve and protect the product stored in Above Ground Storage Tanks. Available in 2" and 2.5" fill and combination fill/vent caps or 2" and 3" atmospheric and pressure tank vent caps.

TANK GAUGES

Tank Gauges for your Above Ground Storage Tank provide exceptional value for your operation and allow you to instantly verify fluid levels. Float and elbow gauges are available for a variety of installations as well as leak gauges for double wall self-contained ASTs

ALSO AVAILABLE

Stair assembly, step assembly, ladder assembly, manual pumps, tank cradles, overhead gravity stands, angle valves, filters and more

QUALITY IN STEEL SINCE 1905

Westeel has offered quality steel storage solutions to multiple industries for over a century. Our comprehensive catalogue of products includes storage and containment solutions for the petroleum, water and industrial sectors as well as a wide range of on-farm and commercial grain handling and storage solutions for today's agriculture industry.

Consistent with Westeel policy of continued research and development of our products, we reserve the right to modify or change information contained in this publication without notice.



PRODUCTS MAY NOT APPEAR EXACTLY AS PICTURED

